



DSMA

For High Intensity Shock Testing

OUR EQUIPMENT. YOUR SUCCESS.

MASS SHOCK AMPLIFIERS

Mass Shock Amplifiers (MSA) are used for testing relatively small specimens with very short duration, high acceleration pulses on shock machines which would not be capable of generating these pulses. There are two models: MSA-89x89 and MSA-305x305.

Both models can be used for generating the most test conditions specified in MIL-STD, ISTA, ASTM, ISO and other internationally and industry recognized standards. Depends on shock systems, the MSA-89x89 can generate accelerations as high as 100,000 g; and the MSA-305x305 can generate accelerations up to 10,000 g at pulse duration as short as 0.2 ms.

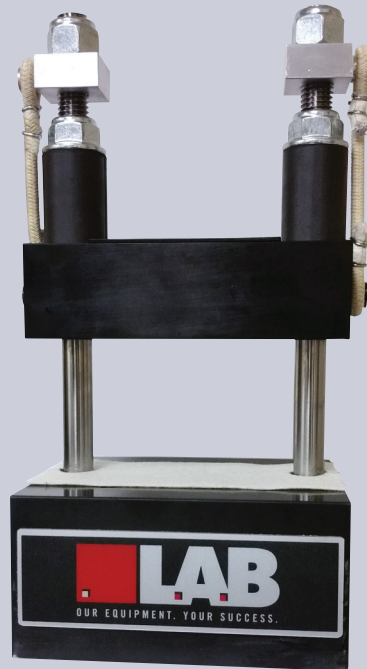

SYSTEM OPERATION

The amplifiers consist of precisely guided secondary shock table and a massive base which is bolted to the top of the table of the primary shock machine. The specimen is mounted on top of the secondary shock table.

The secondary table is held up against high damping elastomer bumpers by elastic shock cords. A high density felt programmer is placed between the secondary table and its base. The thickness of the felt controls the duration of the pulse experienced by the secondary table and the specimen.

Any type of resilient programmer which will produce a pulse duration of about 6 ms or less is used between the primary table of the machine and its base.

While the primary shock table is falling, the secondary table is held approximately 64 mm above its base by the elastic shock cords. When the primary shock table impacts and rebounds from the programmer on the base of the machine, the secondary table continues downward stretching the shock cords. While the primary shock table is moving upward after rebound, the secondary table impacts on the felt programmer and then rebounds against the soft elastomer bumpers and is held against the bumpers by the shock cords. When used on a shock machine with rebound brakes, no secondary impact on the felt programmers occurs because of the high damping properties of the bumpers and the upward pull of the shock cords.

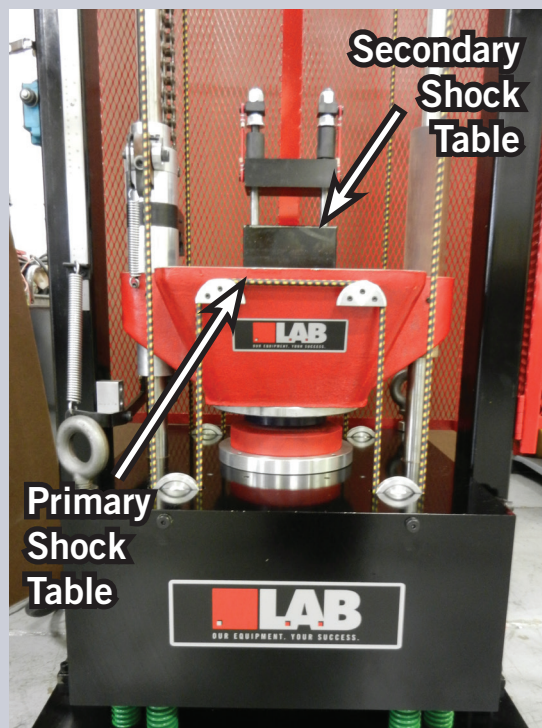

MASS SHOCK AMPLIFIERS

MASS RATIO AND VELOCITY AMPLIFICATION

Because the weight of the secondary table and specimen is much less than the combined weight of the primary shock table and amplifier base which it is impacting against, the secondary table experiences a velocity change which is greater than that experienced by the primary shock table. This velocity amplification ranges from a minimum about 10% for machines with light shock tables to a maximum about 30% for machines with heavy shock tables. A “light” shock table is anything between 9 kg to 45 kg. A “heavy” shock table is anything between 45 kg to 227 kg.

To calculate the maximum performance of the shock amplifier on a particular shock machine, it is necessary to know the machine’s maximum velocity change and the approximate weight of the primary shock table.

$$\text{Secondary Table } \Delta V = \text{Amplification} \times \text{Machine Velocity Change}$$

For example, the performance of both MSA-89x89 and MSA-305x305 would have the following performance on a shock machine capable of producing a velocity change of 9 m/sec and a shock table weighing 136 kg:

MSA-89x89 – the 136-kg table is in the “heavy” range, so the maximum amplification factor is used.

$$\text{Secondary Table } \Delta V = 1.3 \times 9 \text{ m/sec} = 12 \text{ m/se}$$

MSA-305x305 – the 136-kg table is between the “light” and “heavy” range, so an intermediate amplification factor is used.

$$\text{Secondary Table } \Delta V = 1.2 \times 9 \text{ m/sec} = 11 \text{ m/sec}$$

To determine what combination of peak accelerations and pulse durations can be generated on the shock amplifiers, the following formula can be used for half-sine pulses:

$$\Delta V = .02 AT$$

Where $\left\{ \begin{array}{l} \Delta V = \text{Velocity Change in ft/sec} \\ A = \text{Peak Acceleration in g's} \\ T = \text{Pulse Duration in millisecond} \end{array} \right.$

For example, the velocity change required to produce a 10,000 g / .2 ms pulse is

$$\Delta V = (.02) (10,000) (.2) = 40 \text{ ft/sec (12 m/sec)}$$

SPECIFICATIONS

	MSA-89x89	MSA-305x305
Specimen mounting surface	3.5" x 3.5" (89 x 89 mm)	12" x 12" (305 x 305 mm)
Maximum specimen weight	5 lbs (2 kg)	25 lbs (11 kg)
Maximum acceleration	100,000 g	10,000 g
Maximum pulse duration	1.0 ms	1.0 ms
Minimum pulse duration	.05 ms	.2 ms
Velocity amplification	10% minimum 30% maximum	10% minimum 30% maximum
Table weight	1.6 kg	21 kg
Base weight	15 kg	227 kg
Base dimensions	152 mm x 152 mm	305 mm x 457 mm



OUR EQUIPMENT. YOUR SUCCESS.

A Spectral Dynamics Company



L.A.B Equipment, Inc., 1549 Ardmore Avenue, Itasca, IL 60143, USA

Phone: 630-595-4288 Fax: 630-595-5196 www.labequipment.com

EASY-TO-USE SYSTEM

The Mass Shock Amplifiers are very simple to use. The pulse duration is adjusted by changing the thickness of the high density felt programmer. Peak acceleration is controlled by changing drop height or velocity change on the machine.

No adjustment of the elastic shock cords or of any bolt torques are required. When used on machines which product repeatable velocity changes, repeatability of the pulses produced by the shock amplifiers is excellent.

MOUNTING GUIDE

To install the MSA, it may be necessary to back off the adjusting nuts on either side of the adjuster block in order to permit insertion of an Allen wrench between the MSA table and base.

Proper preload can then be applied by positioning the adjusting nuts so that the distance between the bottom surface of the MSA table and the top of the MSA base in $2 - \frac{1}{2}$ (635 mm).

Center the MSA base on the shock machine table and align the mounting holes. Tighten the hold down bolts. If the mating surface appears to be uneven, apply a coat of grease at the interface and then tighten the hold down bolts. This will improve the mechanical coupling.

Model MSA-89x89

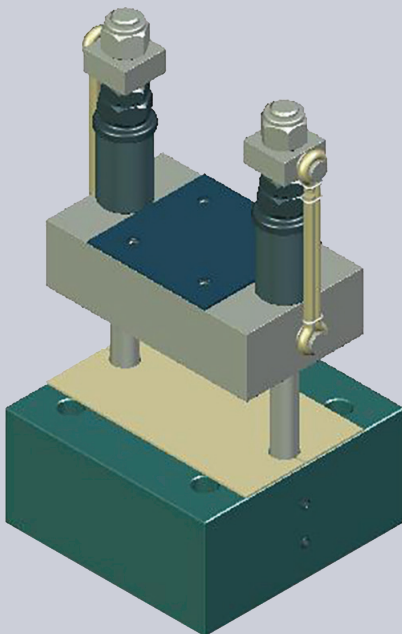

Model MSA-89x89

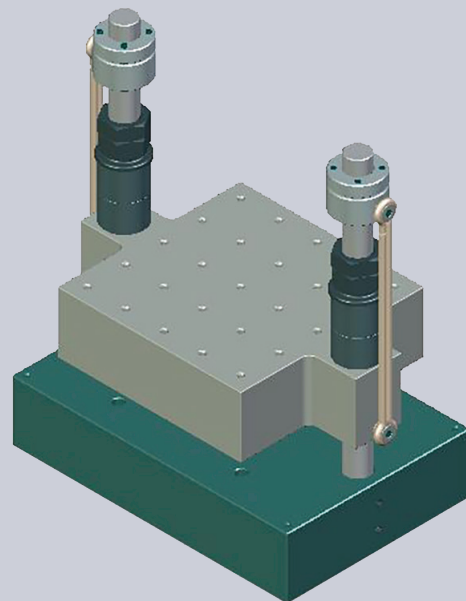

OUR EQUIPMENT. YOUR SUCCESS.

A Spectral Dynamics Company



L.A.B Equipment, Inc., 1549 Ardmore Avenue, Itasca, IL 60143, USA

Phone: 630-595-4288 Fax: 630-595-5196 www.labequipment.com